



TiefbohrSysteme[®] GmbH

DEEP HOLE BORING TECHNOLOGY | EQUIPMENT

Solid Drilling Tools TAN

Type 1450 / 1451

DEEP HOLE DRILLING TOOLS

BORING RANGE Ø61,00 - 144,99 mm

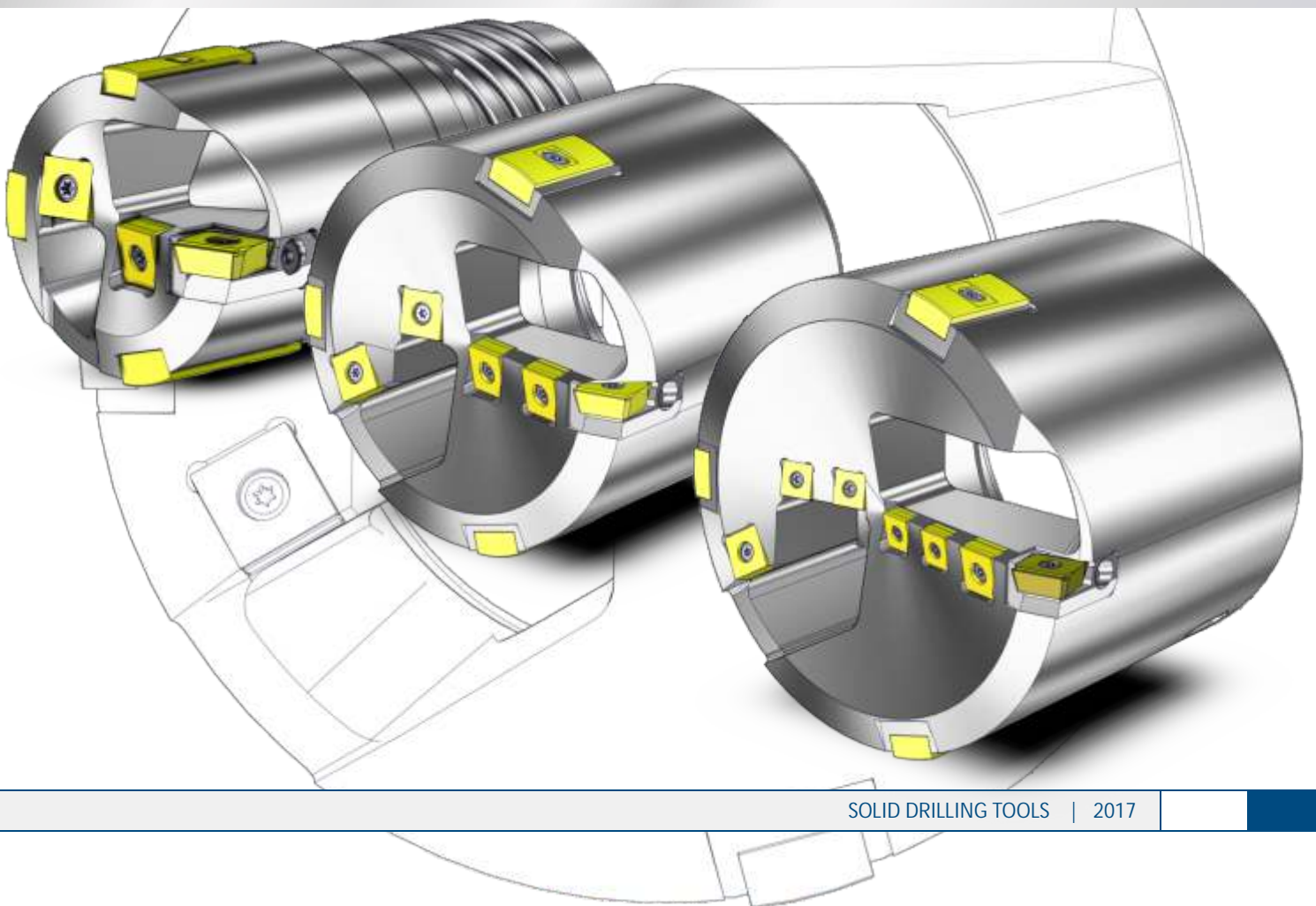

Deep Hole Boring - An Inaccessible World

In today's production world, precision and production strategies are a significant constituent for success. The more complex the production process, the more important are these two factors. deep hole boring our company, BTA-Tiefbohrsysteme GmbH, is the essential partner for implementation even under difficult marginal conditions with high requirements. We are the only company in the world capable of offering our customers everything from inserts to complete, suitable equipment for deep hole boring machines. Our experienced experts are always at your side to ensure proper support from planning your deep hole boring project up to tool services. All this is aimed at your success.

In the company-owned application and research department we can test innovations and special designed tools, customize the tools to user-specific material and train their operators. You will receive tools customized for your application and benefit from our experience.

Our tool systems offer you the following advantages:

- Tools designed for various processes (solid boring, trepanning, counter boring and skiving) with the same effective elements, especially such as inserts and guides. This results in extremely low stocks and simple handling.
- Suitable selection possibilities for tools, corresponding to required boring quality, from simple solid boring to form boring.
- Custom layout of tools for various production requirements to straightness, surface, material and constant wall thickness.
- Equipment matched to the deep hole boring process - from workpiece clamping to vibration damping.
- Production-optimized machinery layout for reducing setup and conversion times.

Here are a few results from production boring with our tools:

- Surface Ra < 0.1 μm e.g. by skiving and roller burnishing
- Mismatch of axes < 0.1mm/m e.g. by pull counter boring
- Hole accuracy < IT8 e.g. by skiving

Benefit from these advantages by cooperating with a strong partner.

BTA-Tiefbohrsysteme GmbH





Contents

Contents	3
Solid Drilling Tools Ø61,00 - 88,99 mm	4
Solid Drilling Tools Ø89,00 - 144,99 mm	5
Spare and wear parts	6

Tool description

- Solid Drilling Tools with tangential arranged inserts (three and more)
- The drill diameter is fixed
- Especially suitable for machining stainless steels
- Equipped with three guide pads
- Available as bta- and up to Ø90,0 as ejector-tool

Tool characteristics

- drilling depth 200 x tool diameter
- surface R_a 1,25 μ m
- mismatch of axes 0,2 mm/m
- drilling accuracy IT9

Solid Drilling Tools Type 1450 / 1451

Boring range Ø 61,00 - 88,99 mm

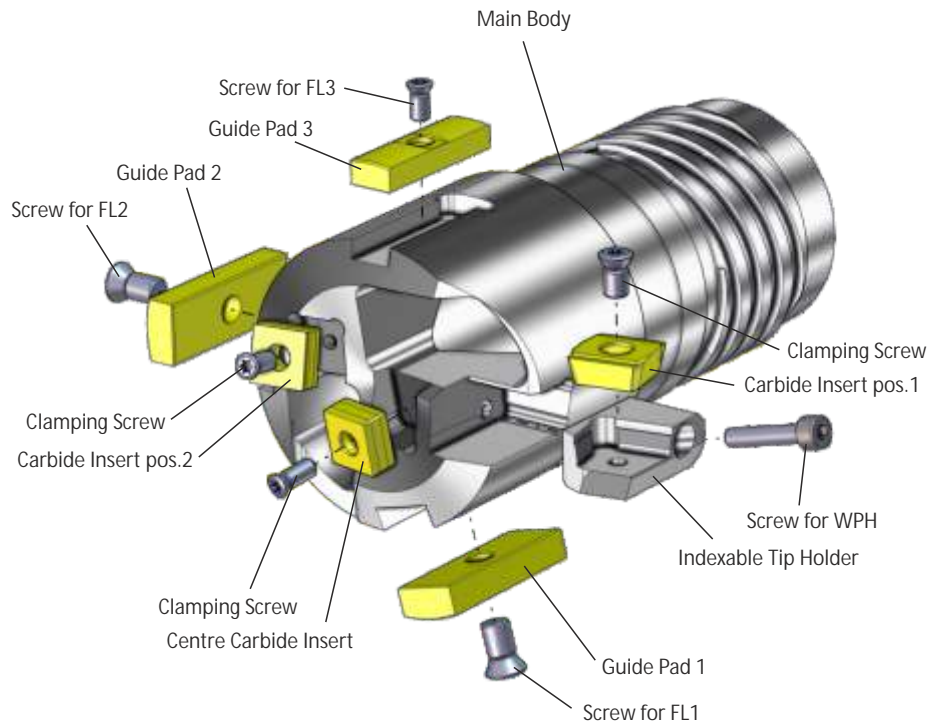

Boring Range	Drill Tube Connection	Carbide Insert	Indexable Tip Holder	Carbide Insert Pos.2	Centre Carbide Insert	Guide Pad FL1 and FL2	Guide Pad FL3
Ø 61,00 - Ø 64,99	56				Z 1-N	FL 10	FL 8
Ø 65,00 - Ø 67,99				Z 2-P			
Ø 68,00 - Ø 70,99	62	A 3	A 3		Z 2-N	FL 14	FL 10
Ø 71,00 - Ø 74,99							
Ø 75,00 - Ø 80,99				68			
Ø 81,00 - Ø 88,99	75	A 4	A 4			FL 14	FL 14

See Page 6/7 for spare and wear parts ordering data

Possible drill tube connection:



BTA-Thread
Type 1450



STS-Thread
Type 1451



Solid Drilling Tools Type 1450 / 1451

Boring Range Ø 89,00 - 144,99 mm

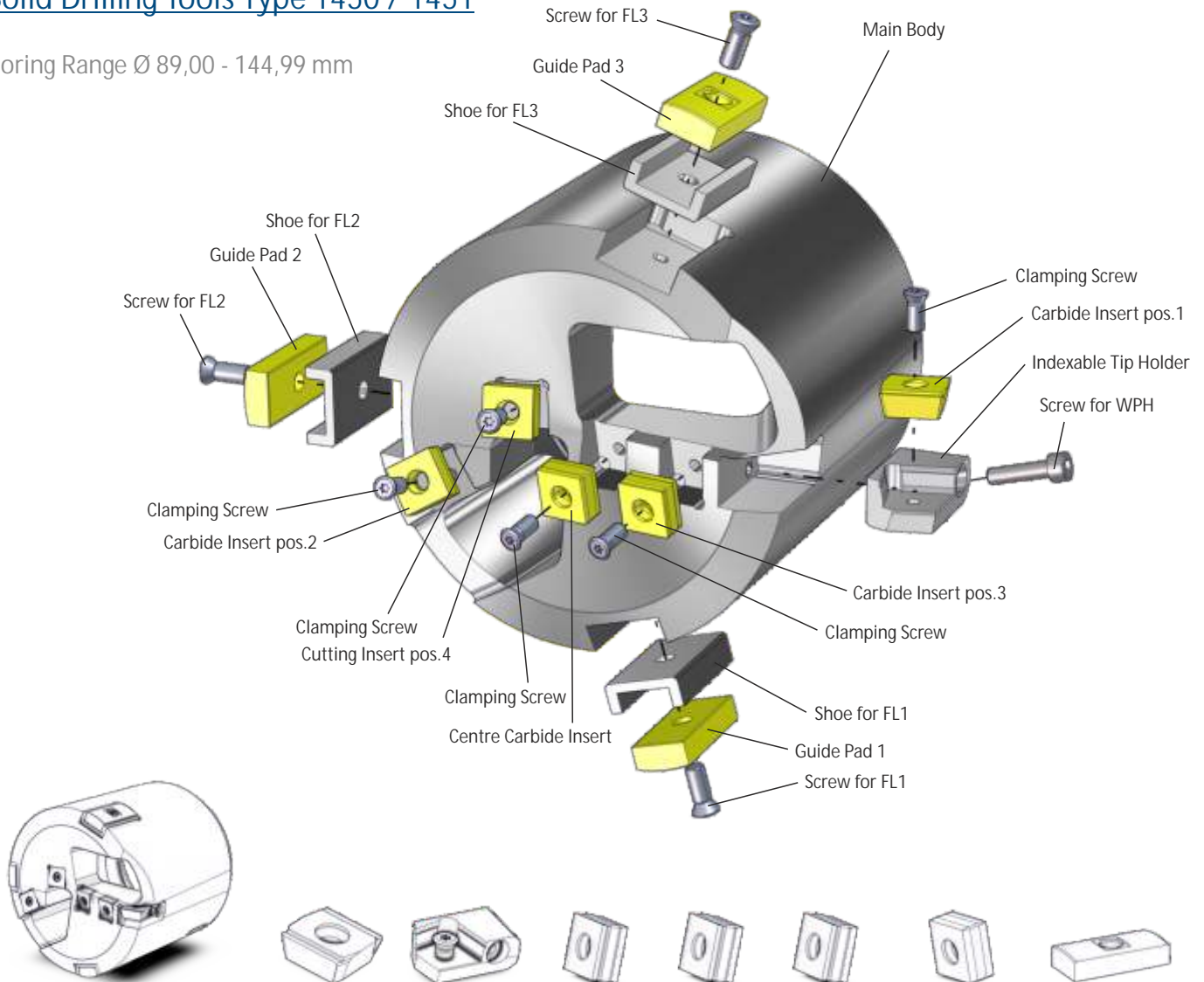

Boring Range	Drill Tube Connection	Carbide Insert	Indexable Tip Holder	Carbide Insert	Carbide Insert	Cutting Insert	Centre Carbide Insert	Guide Pad FL1, FL2 und FL3
Ø 89,00 - Ø 90,99	75			Z 2-P	Z 1-P	Z 1-P	Z 1-N	FL 14
Ø 91,00 - Ø 98,99	82	A 3	A 3					
Ø 99,00 - Ø 110,99	94			Z 2-P	Z 2-P	Z 2-P	Z 2-N	FL 18
Ø 111,00 - Ø 122,99	106							
Ø 123,00 - Ø 134,99	118	A 4	A 4	Z 3-P	Z 3-P	Z 3-P		
Ø 135,00 - Ø 144,99	130						Z 3-N	

Additional diameters on request

See Page 6/7 for spare and wear parts ordering data

Possible drill tube connection:



BTA-Thread
Type 1450



STS-Thread
Type 1451

Spare and wear parts

For Solid Drilling Tools Type 1450 / 1451

Indexable Tip Holder

Size	Ident-No. Indexable Tip	Ident-No. Clamping Screw
A 3	013.9006.K	M4x20 / DIN 912
A 4	013.9008.F	M5x20 / DIN 912



Indexable Tip Holder pos.1

Size	Carbide		Ident-No. Clamping Screw
	P 25 TiN	K 20 TiN	
A 3	013.9133.C	013.9135.X	M5x9,5 T15
A 4	013.9143.Z	013.9145.U	M5x12 T15

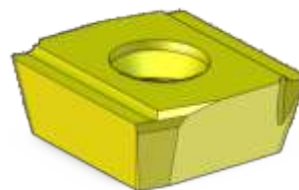

Carbide Insert pos.2 - pos.4

Size	Carbide		Ident-No. Clamping Screw
	P 25 TiN	K 20 TiN	
Z 1-P	013.9013.N	013.9015.J	M3x9 T9
Z 2-P	013.9023.K	013.9025.F	M4x10 T15
Z 3-P	013.9033.G	013.9035.C	M5x12 T15

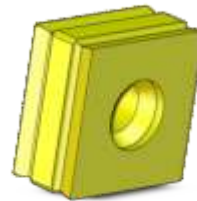

Centre Carbide Insert

Size	Carbide		Ident-No. Clamping Screw
	P 25 TiN	K 20 TiN	
Z 1-N	013.9043.D	013.9045.Z	M3x9 T9
Z 2-N	013.9053.A	013.9055.V	M4x10 T15
Z 3-N	013.9063.W	013.9065.S	M5x12 T15

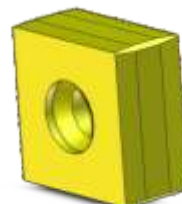

Guide Pads



Position	Boring Range	Description	Radius	Carbide		Shoe for Guide Pads	Screws for Guide Pads
				TiN coated	ML coated		
Guide Pad 1 and 2	Ø 61,00 - Ø 67,99	FL 10	28	016.9226.A	019.6680.L	015.2246.N	M4x8,2 T15
	Ø 68,00 - Ø 110,99	FL 14	30	016.9229.T	019.6681.M		M6x12 T20
	Ø 111,00 - Ø 144,99	FL 18	40	014.4761.R	019.6682.N		M6x16 T20
Guide Pad 3	Ø 61,00 - Ø 67,99	FL 10	20	016.9223.G	019.6679.K	015.2246.N	M4x8,2 T15
	Ø 68,00 - Ø 110,99	FL 14	30	016.9229.T	019.6681.M		M6x12 T20
	Ø 111,00 - Ø 144,99	FL 18	40	014.4761.R	019.6682.N		M6x16 T20

Spare and wear parts

For Solid Drilling Tools Type 1450 / 1451

Torx-Screws und Wrenches

Size	Length	Ident-No. Clamping Screw	Torx Size	Ident-No. Torx-Wrench
M2,5	5	010.8405.U	T8	010.8812.F
	10	010.8778.C		
M3	5,1	014.4771.N	T9	008.1104.D
	5,8	014.4772.L		
	6,2	014.4773.J		
	7,4	008.1065.L		
	9	010.7674.V		
M3,5	15	010.8779.A	T15	008.7219.C
M4	8,2	008.1066.J		
	10	010.7499.M		
M5	12,5	010.8172.R		
	9,5	014.4779.V		
M6	12	008.1067.G	T20	008.7220.T
	16	008.5807.U		
M6	12	008.1068.E	T20	008.7220.T
	16	010.7708.F		



Socket Head Cap Screws and Wrenches

Size	Length	Ident-No. Clamping Screw	SW Size	Ident-No. Hexagon Wrench
M4	16	008.5111.K	SW 3	008.6741.T
	20	008.8112.H		
M5	20	008.5117.W	SW 4	008.5837.K





BTA-Tiefbohrsysteme GmbH
Hainkämpe 12
28832 ACHIM
GERMANY

Tel. +49 (0) 4202 / 96 84 - 5
Fax. +49 (0) 4202 / 96 84 - 70

e-mail info@bta-tiefbohrsysteme.com
Internet www.bta-tiefbohrsysteme.com

Our program:



The catalogs are for information only and not subject to change service. Printing errors, mistakes and technical changes excepted. For further information please contact the above address.